

SERIES SPORTS AND RECREATION VEHICLE
OWNER'S MANUAL

GK650

CONTENT

Foreword	2
1. The performance, technical parameters and structure of Go kart	3 - 5
1.1 Performance and Specifications	
1.2 Parts and their locations	
2. The use of Go kart	6 - 13
2.1 Caution and safety note	
2.2 Caution signs	
2.3 Instrument and control	
2.4 Before riding	
2.5 Basic operation	
2.6 Grinding-in	
2.7 Circuit diagram	
3. Maintenance	14 - 20
3.1 Engine maintenance	
3.2 Periodical maintenance	
3.3 Torque of tightening of the main bolts and nuts	
4. Trouble shooting	21 - 24
5. VIN number	25
6. Sketch of part	26 - 41

FOREWORD

Congratulations on having this new kart.

We recommend that you read this owner's manual before you ride the kart. This manual contains the vehicle structure, operation instructions, safety information and some helpful suggestion. The manual has a special section concerning maintenance. To protect your investment, we strongly recommend you to keep your go-kart well maintained. In case of any problem on your Kart, please refer to the trouble-shooting section. We hope you enjoy riding of your vehicle, and we would appreciate feedback or comments from you.

Our company reserves all the right to revise and explain this manual, and we reserve the right to improve, without notice beforehand, the product after publishing this manual. Some pictures in this manual are sketch maps for reference. In case of any deviation from the material objects, please refer to the actual items.

Copyright Reserved ©

1.The performance, Technical parameter and Structure of Go kart

1.1 Performance and Specifications

Model	GK650-2A	Displacement	0.64L
Length	2940mm	Bore×stroke	76×71 mm
Width	1690mm	Compression ratio	8.4:1
Height	1570mm	Rated power	14kw/4500r/min
Wheelbase	2230mm	Max. torque	36N.m/2500r/min
Front wheel track	1497mm	Ignition	CDI
Rear wheel track	1460mm (57.5 inches)	Lubrication	Forced lubrication & splash lubrication
Ground clearance	215mm (8.5 inches)	Start	Electronic
Max speed	80km/h	Gear shift	4 + 1 (REV)
Braking length	<7m(30km/h)	Spark plug	Torch T4196J
Climbing capacity	≤55°	Gross weight	467kg
Net weight	397kg	Fuel type	RQ-93 (unleaded)
Loading capacity	2person or 250kg	Engine oil type	SE engine oil applicable for gasoline engine
Oil mass	2.5 L	Suspension	Front wheel
Gear box oil	2 L		Rear wheel
Fuel tankage	20 L	Brake	Front wheel
Cooling liquid	3.6 L		Rear wheel
Engine model	LJ276M	Tyre	Front wheel
Type	2cylinders 4 stroke liquid cooling		Rear wheel
Battery	12V 32 Ah	Tyre pressure	Front wheel
Head light/aux. light	12V 55W/20W		Rear wheel
Fuse	20A	Rear light and brake light	12V 5 W /10W
Min. radius of turn	5.5m	Fuel consumption per100km	8L
1st gear transmission ratio	4.111	4th gear transmission ratio	1.000
2nd gear transmission ratio	2.559	Reverse gear transmission ratio	4.271
3rd gear transmission ratio	1.654		

1.2 Component location and structure

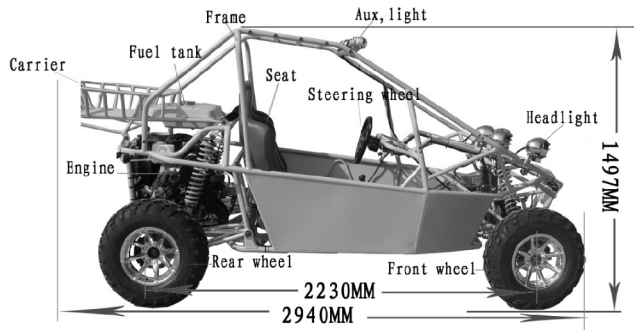
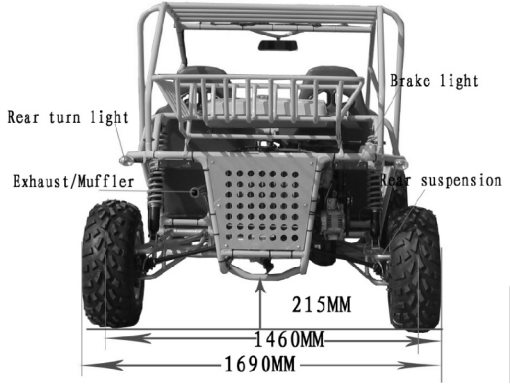
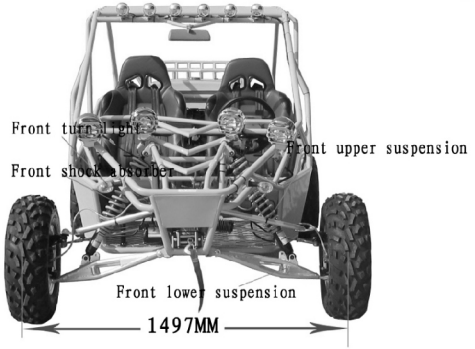

Fig 1



2. The use of Go kart

2.1 Safety Note

Read this owner's manual carefully and make sure you understand it completely before driving this kart.

People under age of sixteen are not allowed to drive this kart. This kart is designed and manufactured for off-road use only. Operation on public streets, roads or high ways is illegal.

Please make sure to wear an approved motorcycle helmet and have the seat belt well fastened before driving the kart. Do not drive this kart at night. It's dangerous to drive on an unknown road. Keep a safe distance between your kart and other vehicles. Never risk drunken driving or drive the kart after taking medicine, which will endanger your driving and result in injury even death. Check fuel level before the kart is used. Never refuel the tank while the engine is hot or running. Spilled gasoline should be wiped off prior to starting the engine. Don't drive your kart indoors. Exhaust contains a kind of tasteless, odorless and poisonous gas called carbon monoxide.

2.2 Caution signs



Fig 4



Fig 5



Fig 6



Fig 7

2.3 Instrument and control

(1) Major switches are located on the right side of the steering wheel.

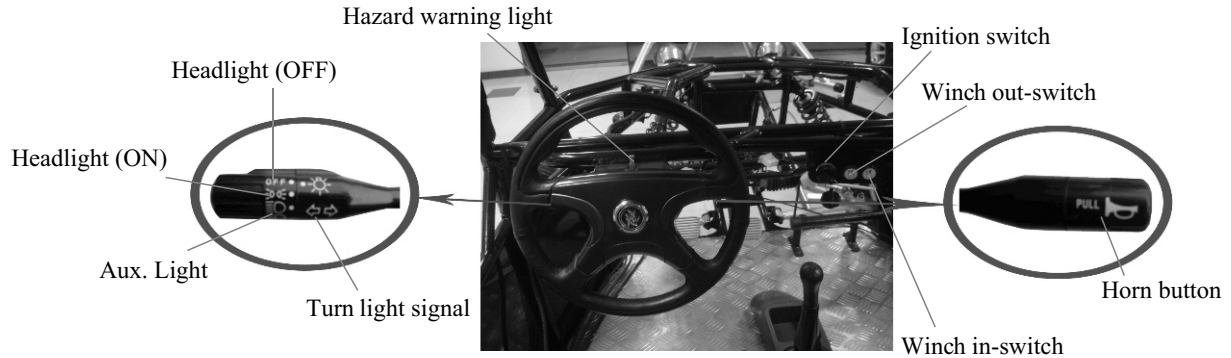

Fig 8

(2) Light switch is located on the left side of steering wheel. Horn button is located on the right side of steering wheel.

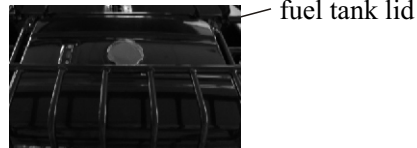

Fig 9

(3)Fuel tank

Fuel tank is located close to the rear carrier of the kart. Turn the lid counterclockwise to open and then refuel. The tank capacity is 20L.

(4) Fuel valve

Fuel valve is located under the fuel tank, and it has two positions, namely vertical (On) and level (Off).

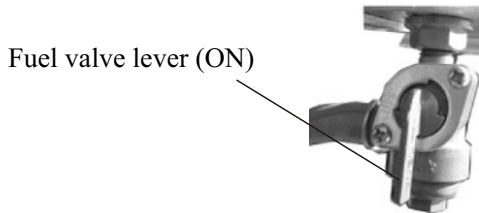

Fig 10

When the lever is vertical, fuel valve is open.

When the lever is horizontal, fuel valve is closed.

(5) Brake pedal

Brake pedal is underneath the right side of steering wheel. It controls the front and rear brake discs, operated by right foot. When you release your foot from the brake pedal, it will automatically return to its normal position.

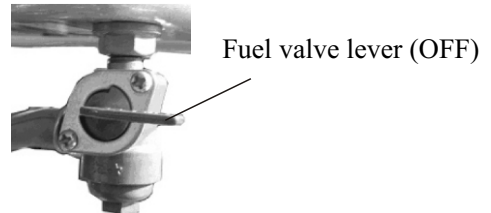

Fig 11

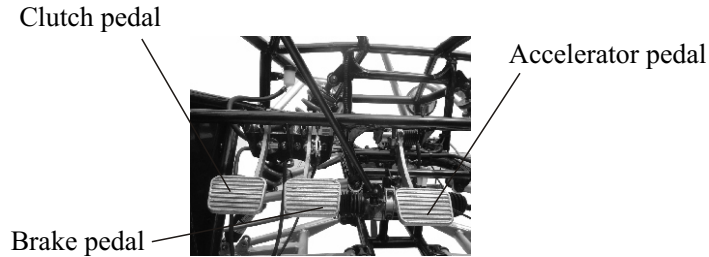

Fig 12

(6)Clutch pedal

Clutch pedal is underneath the left side of steering wheel, and controlled by left foot.

(7)Accelerator pedal

Accelerator pedal is located to the right side of the brake pedal and controlled by right foot.

(8) Gear shifting

Gear shift lever



Fig 13

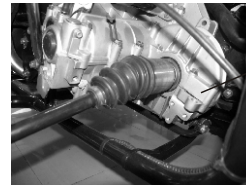

Fig 14

(9)The gear shift lever controls velocity of the kart

(10) Gear box: 4 forward shifts +1 reverse shift

(11) The seat back lock lever is underneath the seat, pull up the lever to adjust the seat, when satisfied, release the lever to lock the position.; seat location adjuster is in the inner side of the seat, pull up to adjust , when satisfied, release the lever to lock

Seat back lock switch

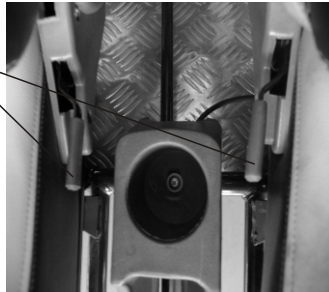

Fig15

Seat location adjuster

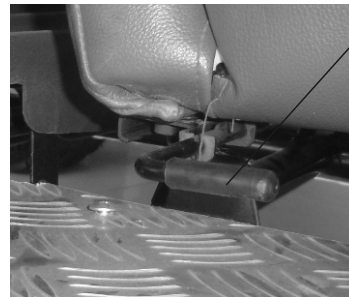

Fig16

(12) Steering side rod

Front wheel alignment can be accomplished by actual use of steering side rod. (The angle of inner obliquity is 1°, normally no need to adjust)

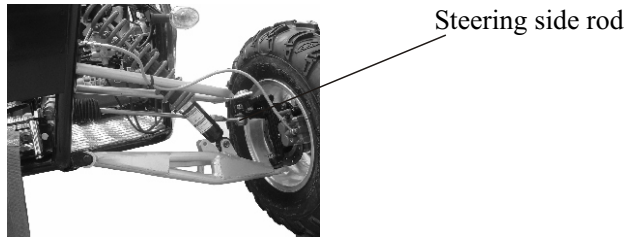

Fig 17

2.4 Before riding

Please check all the following items before driving.

Items	Purpose
Steering	(1) Smoothly (2) No obstacle (3) No clearance
Brake	(1) travel length of pedal is proper (2) No slippery.
Tyre	(1) Proper pressure (3) No crack or cut.
Fuel	Keep enough fuel for intended driving distance
Light	Check all the lamps headlights, tail lamps, stop lamps.
Oil	Check if the oil is enough
Battery	Check the electrolyte level, fill some if necessary

2.5 Basic operation guide

Driving this Go Kart is the same as driving a car.

2.6 Grinding in

Proper grinding-in of new kart is very important to prolong the life span of the vehicle and achieve its best performance. During the initial 10 hours of your driving, limit the driving speed to 55km/h to avoid early damage of parts due to high driving speed.

2.7 Circuit diagram

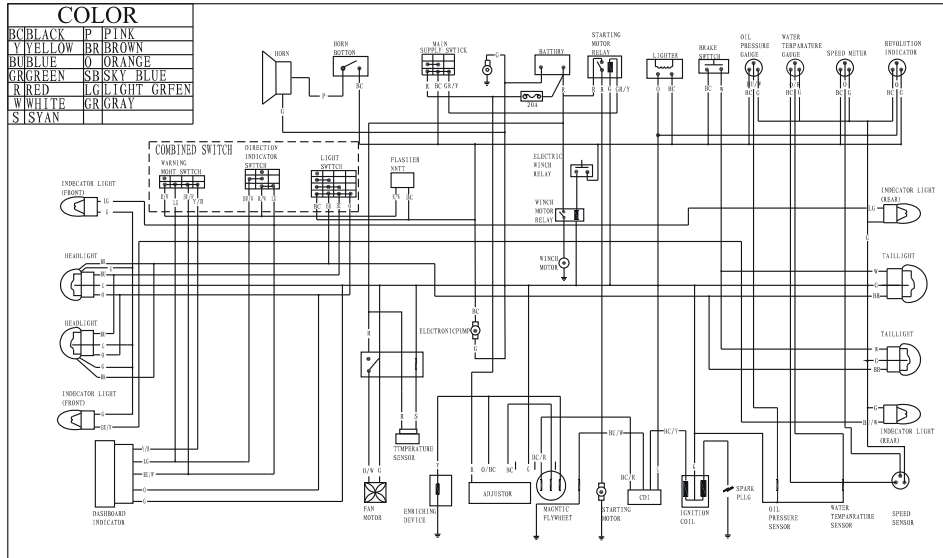

3 Go Kart Maintenance

3.1 Engine maintenance

(1) #93 or above unleaded gasoline is recommended.

Note: using unleaded gasoline can extend the life of spark plug

(2) A. How to choose engine oil

User should choose proper type of engine oil according to the local temperature. Please refer to Fig16.

a 20W - 40

b 10W - 40

c 10W - 30

d 5W - 30

E 5W - 20

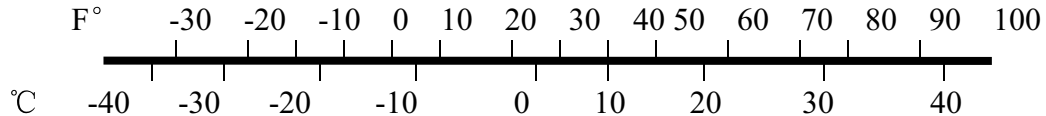

B. Oil Level: The level of engine oil should be between upper scale and lower scale.

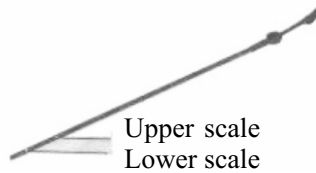

Fig 19

C. Oil Filling:

Oil should be filled through filling port. After oil filling, let the engine run in idle for 3-5 minutes and then check the oil level; add enough if it's inadequate

oil filling port

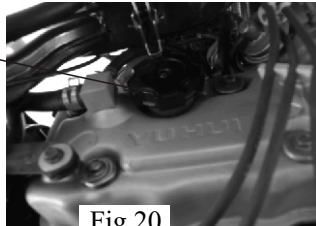
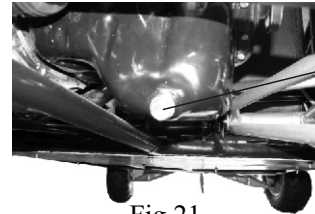

Fig 20



Oil drain bolt

Fig 21

D. Changing Oil: Unscrew the oil drain bolt to let out old oil ; screw down the bolt when all the old oil is let out before new oil is filled in.

E. Gear oil AP/GL4SAE75/85,85,80/90 or 90 are recommended for gearbox; the amount required is 2 L; and the oil level should be between upper scale and lower scale.

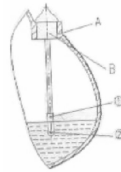

Fig 22

(3) Cooling liquid

A. Cooling system of the engine must be filled with adequate cooling liquid. Cooling liquid is a mixture of water and coolant. Water and coolant should be mixed by a specific ratio (the ratio 60% water and 40% coolant in summer, water and coolant ratio 50% in winter). The water must be distilled water or boiled water. Do not use water direct from well, river or other unclean water.

The filling port of the radiator

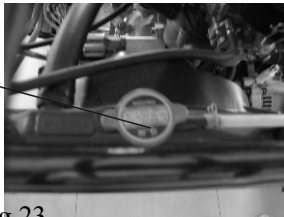

Fig 23

auxiliary tank



Fig 24

B. After 5-minute running of the engine, stop it and wait for 15 minutes before you inspect the cooling water level. If it is still not enough, add more cooling water to the limit line.

3.2 .PERIODICAL MAINTENANCE

The maintenance intervals in the following table are based on average riding conditions. Unusual condition requires more frequent service.

Items \ Time of service	Initial service (First week)	Monthly	Quarterly	Yearly
Tyre pressure/wear	I	I		
Brake performance	I	I		
Tightness of fasteners	I	I		
Air cleaner			C	I
Carburetor	I	A		C
Spark plug			C, A	
Engine oil		I	R	
Gear box oil		I	R	
Oil filter screen			C	
Chassis		C, I	L	
Fuel switch/Fuel tank		I		C
Battery			I	
Valve clearance of engine			A	
Control cables		I		
Cooling liquid		I		R

Remarks: A : To adjust; C: To clean; I: To inspect, clean or replace if necessary; L: To lubricate; R: To replace.

The following are some instructions during the periodical check:

1). Engine oil check

Oil gauge



Fig 25

Check the oil gauge. Make sure there is enough lubricating oil; the capacity is 4.5L. (Engine 2.5L, Transmission: 2L).

2.) Fuel tank check

Check for enough fuel in the fuel tank. The fuel tank capacity is 20L. RQ93 unleaded gasoline is recommended. Do not fill too much fuel, or the fuel may overflow and cause a fire.

3.) Tyre pressure check

Check if the tyre pressure is normal. The recommended tyre pressure is 100kpa; Check if there are any metal fragments or nails stuck in the tyre; if so, remove them immediately.

Check if there is any crack or severe tear on the tyre, replace the tyre if necessary.

4.) Battery check

The normal voltage should be above 12.8V; Keep the terminals clean and the connections tight.; If the voltage is below the normal condition, remove the battery to recharge

5.) Chassis check

After cleaning the chassis, inspect the body, front and rear suspensions, rocker arm rear, axle and fasteners and check if there is any weld failure, crack or loose connections. Apply some weight to the front bumper and the rear carrier to check the performance of front and rear shock absorber..

6.) Brake system check

The brake pedal must have proper length of travel. Length of travel is the distance from brake pedal's idle position to it's working position, and it is about 15-25mm.

Brake master cylinder

Clutch master cylinder



Suspension

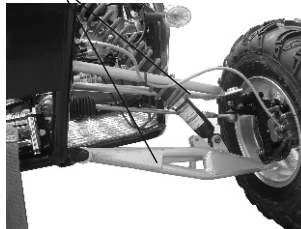

Sphero joint



Periodically inspect the thickness of the brake disc. It should be replaced in case of any wear of over 1mm.

Periodically inspect the level of the brake fluid in the oil cup. When the brake fluid is below the required level, fill new DOT4 brake fluid.

Always keep the brake discs and the brake pads clean.

7) Maintenance guide

Repair should be done by professional service center, unless the owner has a complete set of repairing tools and maintenance manuals. Stop the engine before repairing the kart.

WARNING: If your kart has experienced a collision or overturn, please carefully inspect each part of the kart, such as the frame, suspension and steering device; Driving damaged kart is forbidden as it will endanger yourself.

3.3 Torque of tightening the bolts and nuts :

Number	Item	Required torque	
		N. M	Kfg m
1	Front swing arm bolt	28 ~ 32	2.8 ~ 3.2
2	Rear swing arm bolt	43 ~48	4.3 ~4.8
3	Rear swing arm nut	55 ~ 60	5.5 ~ 6.0
4	Nuts at front and rear hub	55 ~ 60	5.5 ~ 6.0
5	Nuts at front and rear rim	43 ~48	4.3 ~4.8
6	Bolts for roll cage	28 ~ 32	2.8 ~ 3.2

4. Trouble Shooting

(1) Engine does not start, or suddenly stops during driving, first inspect electrical circuit status and then check for enough fuel in the fuel tank, and then perform following inspection.

Troubles	Causes	Solving methods
Engine suddenly stops.	(1)Spark short circuit. (2)Carbon accumulation on spark plug. (3)Ignition coil is damaged. (4)Piston seized in the cylinder.	(1)Clean or replace (2)Remove accumulated carbon. (3)Replace. (4)Repair or replace
Engine runs more and more slowly, until finally stops running.	(1)Fuel dust clogs. (2)Cylinder head blows or gasket is Damaged.	(1)Clean (2)Tighten or replace

(2) Engine difficult to start

Troubles	Causes	Solving methods
Fuel fail to flow into the carburetor.	(1)Fuel screen clogged (2)Fuel pipeline clogged. (3)Fuel in the fuel tank exhausted. (4)Fuel valve clogged.	(1)Clean and wash (2)Clean and purge. (3)Refuel. (4)Clean and purge

Troubles	Causes	Solving methods
Inspection finds the spark is weak.	(1)Spark plug damaged. (2)The clearance adjustment of the spark plug is improper. (3)CDI components have defects. (4)The ignition coil is damaged.	(1)Replace. (2)Adjust. (3)Replace (4)Replace
Spark plug fails to create spark.	(1)Spark plug is damaged. (2)Spark plug is dirty or wet or shorted out. (3)The clearance adjustment of the spark plug is improper. (4)CDI components have defects. (5)The ignition switch is damaged. (6)The ignition switch has bad Contact. (7)Electrical wire is damaged.	(1)Replace. (2)Clean (3)Adjust. (4)Replace (5)Replace (6)Replace (7)Repair or replace.

Troubles	Causes	Solving methods
The cylinder compression pressure is too low.	(1) Too much wear out on the cylinder or piston ring. (2) Piston ring gets stuck (3) Cylinder head gasket is damaged. (4) Spark plug is loose. (5) Cylinder head has air leakage and is tightened unevenly.	(1) Repair or replace. (2) Repair (3) Replace (4) Properly tighten (5) Properly tighten

(3) Abnormal sound from Engine

Troubles	Causes	Solving methods
It is noisier as the rpm increases.	(1) Too much clearance between piston and cylinder. (2) Piston ring is too loose. (3) Too much wear out at the crank bearing	(1) Repair the cylinder or Replace it. (2) Replace (3) Replace

(4)Braking is bad

Troubles	Causes	Solving methods
Braking is not effective	(1)Excessive wear out at the brake pads. (2)Brake pads are dirty. (3)Brake disc wears out or stained with Oil. (4)Too much idle travel (5)There is air in the hydraulic braking System.	(1)Replace (2)Clean. (3)Clean or replace (4)Adjust (5)Eliminate air

(5)Fuel consuming is too much

Troubles	Causes	Solving methods
Fuel consuming too much	(1)Carburetor adjustment is not proper (2)Fuel pipeline leakage (3)Carburetor float dose not work (4)Brakes drag (5)Tyre pressure is not enough (6)Engine works improperly (7)Too much dirt in the air cleaner and cause it clogging and too thick mixed air	(1)Adjust the carburetor (2)Find and repair the leakage (3)Repair or replace (4)Adjust until brakes move smoothly. (5)Inflate the tyre to its prescribed pressure (6)Inspect the engine (7)Maintain the air cleaner, and clear the dirt and dust, or replace the filter

5. VIN

5.1 Product identification number:

Please take down the frame number and engine number for reference. The frame number is stamped on back of the kart.

01

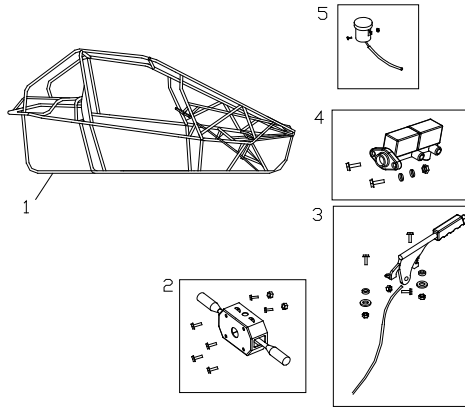

Ref. No	Part No.	Description	Quantity
1	01531X	Frame	1
2	0408	Switch box	1
3	030113	hand brake	1
4	03110	Brake master pump	1
5	03206	Oil cup	1

02

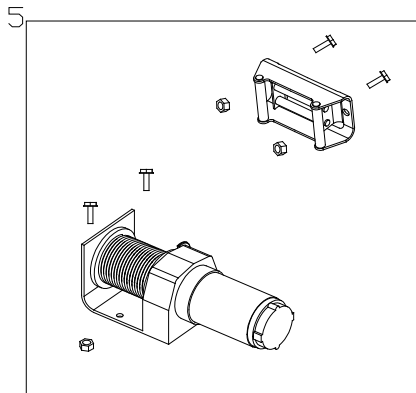
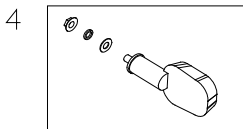
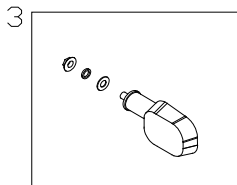
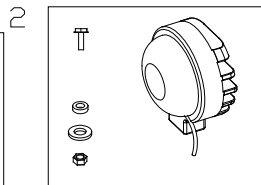
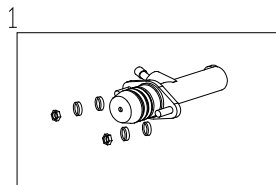

Ref. No	Part No.	Description	Quantity
1	030203	Clutch pump	1
2	0404	Head light	2
3	0403	Rear turn light	2
4	0403	Front turn light	2
5	041	Winch	1

03

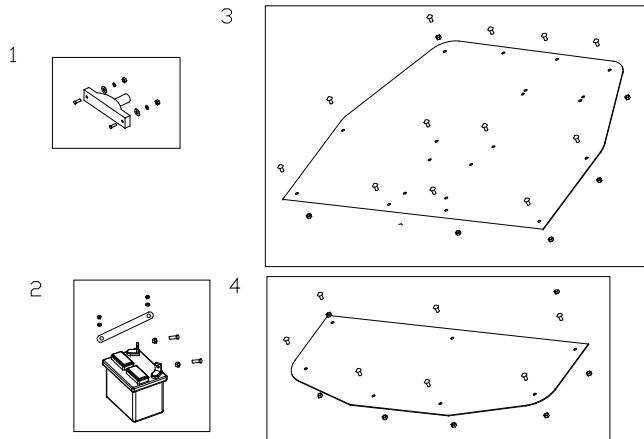

Ref. No	Part No.	Description	Quantity
1	0405	Rear light	2
2	0402	Battery	1
3	1104	Front metal floor	1
4	1109	Rear metal floor	1

04

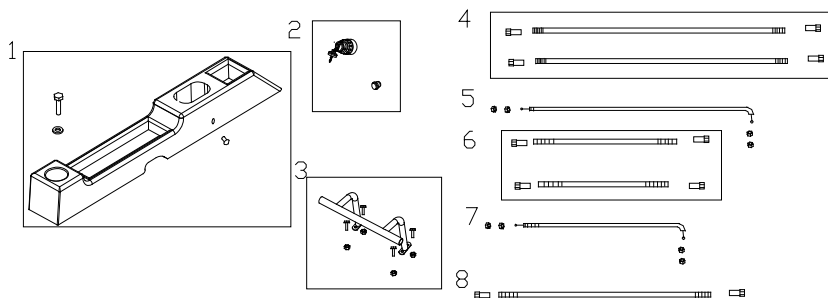

Ref. No	Part No.	Description	Quantity
1	0803	Box	1
2	0410	Ignition switch	1
3	015203X	Foot rest	1
4	030107	Rear brake hose	2
5	030302	Throttling line	1
6	030104	Front brake hose	2
7	03011302	Hand brake line	1
8	03000008	Clutch pipe	1Set

05

1

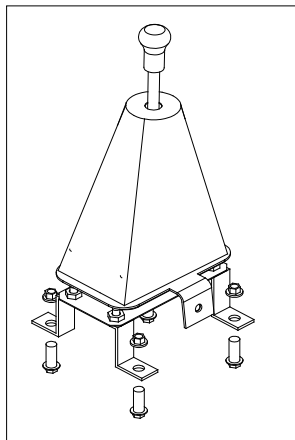

2



3

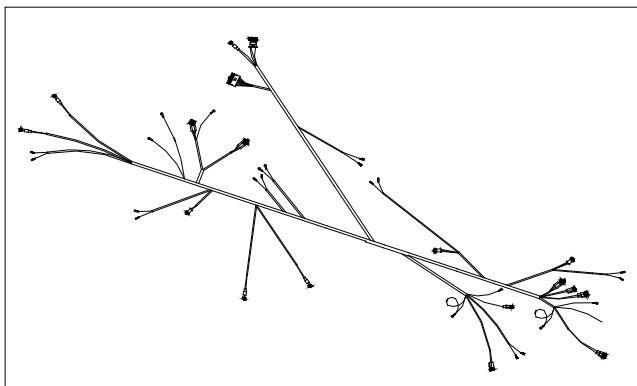

Ref. No	Part No.	Description	Quantity
1	0802	Gear shift lever	1
2	0401	Horn	1
3	0412	Electric cable	1

06

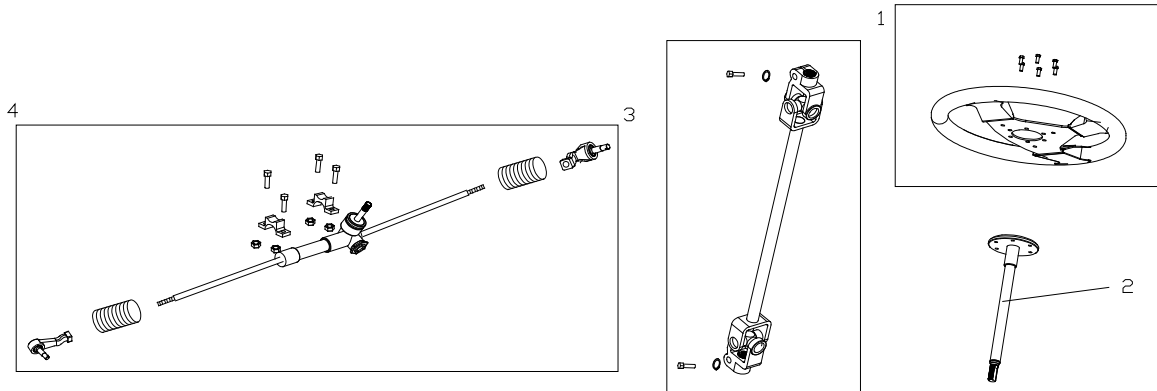

Ref. No	Part No.	Description	Quantity
1	0702	Steering wheel	1
2	0701	Steering shaft	1
3	0704	Steering universal joint	1
4	0703	Steering box	1

07

1

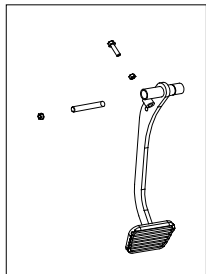

2

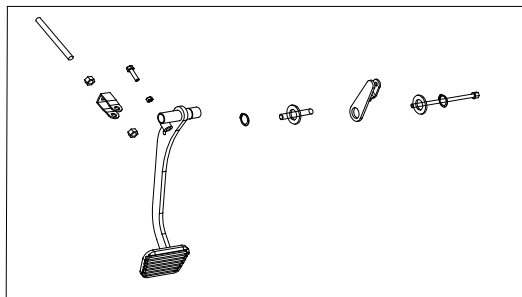

3

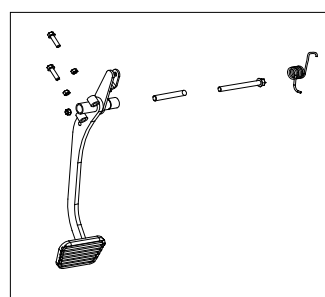

Ref. No	Part No.	Description	Quantity
1	030201	Clutch pedal	1
2	030101	Brake pedal	1
3	030301	Gas pedal	1

08

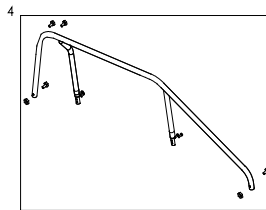
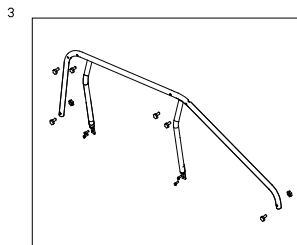
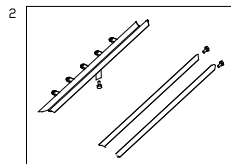
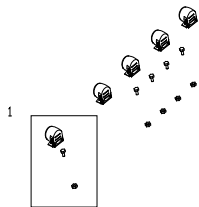

Ref. No	Part No.	Description	Quantity
1	0406	Fog light	5
2	01520103X	Frame (cross member)	4
3	01520102X	Frame (right main)	1
4	01520101X	Frame (left main)	1

09

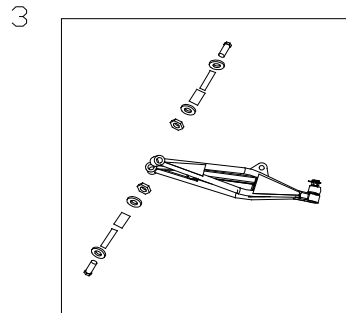
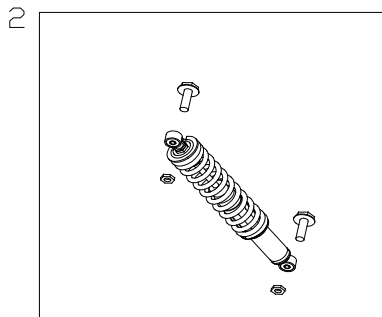
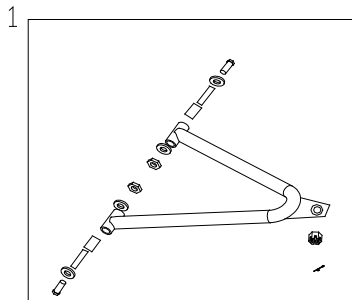

Ref. No	Part No.	Description	Quantity
1	0501	Front upper suspension arm	2
2	0604	Front absorber	2
3	0502	Front lower suspension	2

010

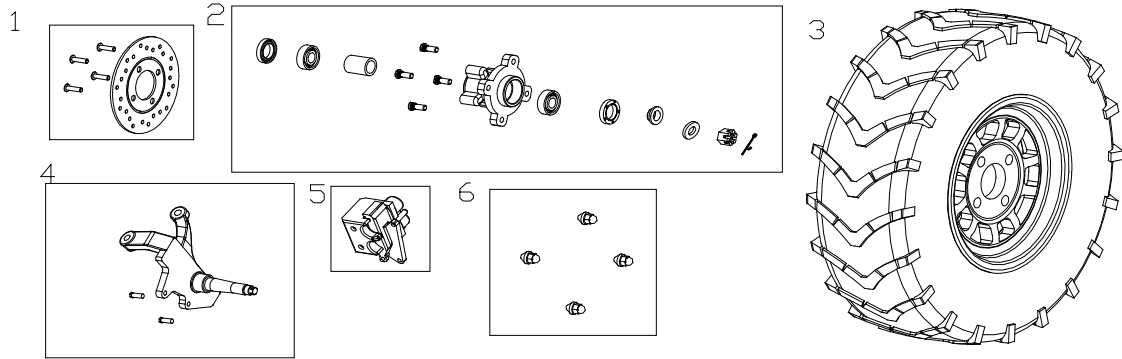

Ref. No	Part No.	Description	Quantity
1	030109	Front brake disc	2
2	0506	Front hub	2
3	0505	Front tyre	2
4	0503X/0504X	(Right/left) Steering axle	1Set
5	030102/030103	Front brake pump	1Set
6	900049	Front hub nut	8

011

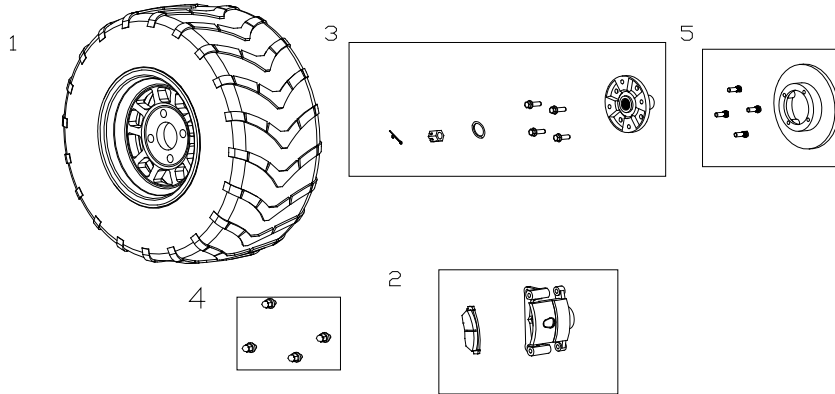

Ref. No	Part No.	Description	Quantity
1	0603	Rear tyre	2
2	030105/030106	(Right/left) Lower brake pump	1Set
3	0605	Rear hub	2
4	900049	Rear hub nut	8
5	030112	Brake disk disc	2

012

1

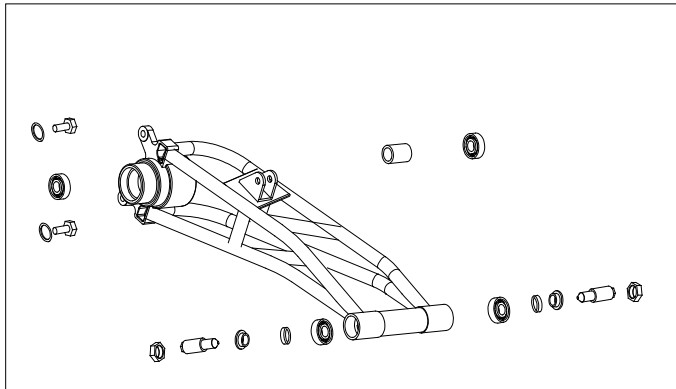

2

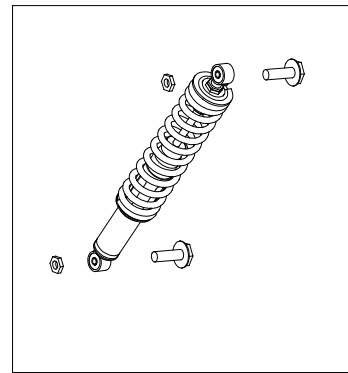

Ref. No	Part No.	Description	Quantity
1	0602X/0601X	(Right/left)Control arm	1Set
2	0604	Rear shock absorber	2

013

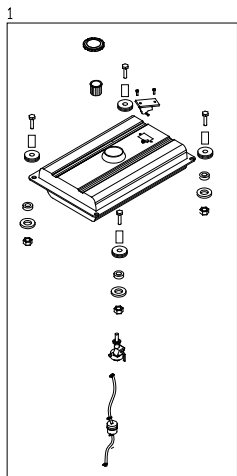

2

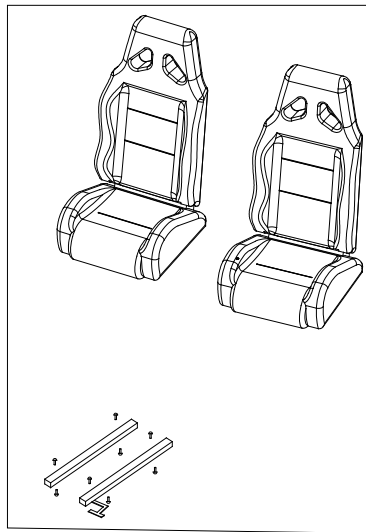

Ref. No	Part No.	Description	Quantity
1	025206	Fuel tank	1
2	0901	Seat	2

014

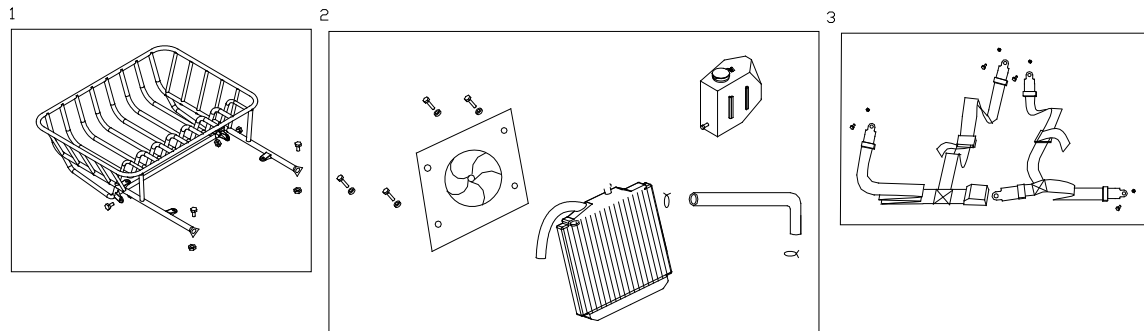

Ref. No	Part No.	Description	Quantity
1	015204	Carrier	1
2	025205	Radiator	1
3	0902	Four-point safety belt	2

015

2

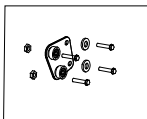

3

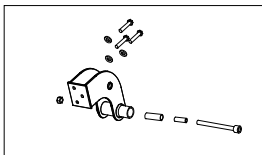

4

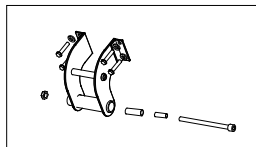

1

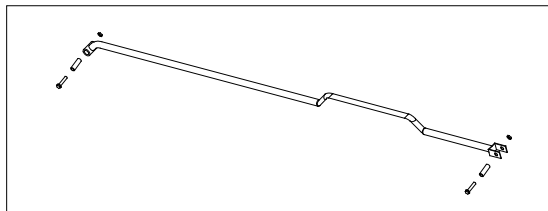

Ref. No	Part No.	Description	Quantity
1	0801X	Gear shift rod	1
2	025203	Engine retainer	1
3	025202	Rear engine support	1
4	025201	Front engine support	1

016

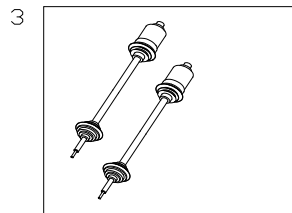
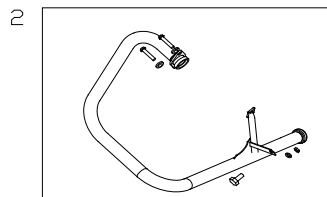
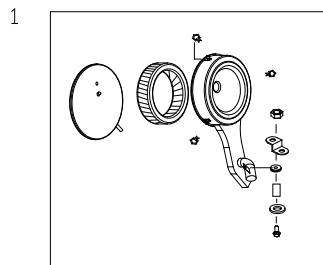

Ref. No	Part No.	Description	Quantity
1	025207	Air filter case	1
2	025204	Exhaust pipe	1
3	0606	Drive axle	2

